

Gas-Fired Cast Iron Steam Boiler

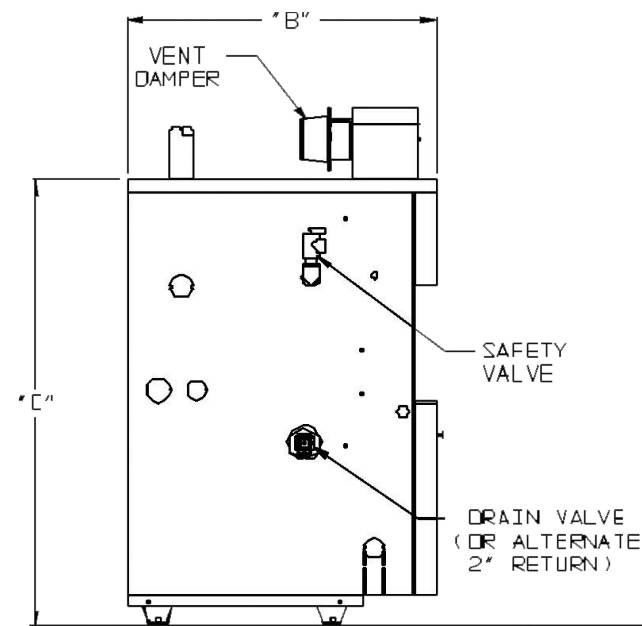

Standard Features

- Natural gas (LP conversion kit available)
- Electronic ignition
- Built-in draft diverter fits in low spaces
- Cast iron heat exchanger, meets ASME boiler code and pressure vessel code
- Metal section connectors resist chemicals, increase the life of the boiler
- Fully assembled
- Fully packaged
- Insulated jacket
- Pressure limit
- 15 PSI safety valve
- Honeywell gas valve
- Hydrolevel probe-type LWCO
- Steam pressure gauge
- Flame roll out switch
- Blocked vent switch
- Vent damper
- Drain valve
- 10-year limited warranty, 1-year manufacturer's warranty on parts



LEFT SIDE VIEW

Technical Information

Model	Dimensions (inches)				AFUE%	Input Rate (MBH)	DOE Heating Capacity (MBH)	Net AHRI Steam (MBH)	Steam (Square Feet)	Approx. Shipping Weight (Pounds)
	A	B	C	Flue Collar Diameter						
FORCETEAM03	12 3/4"	28"	40 7/16"	4"	81.9	69	56	42	175	350
FORCETEAM04	16"	28"	40 7/16"	5"	82.0	103	84	63	263	420
FORCETEAM05	19 1/4"	28"	40 7/16"	6"	82.0	138	113	85	354	485
FORCETEAM06	22 1/2"	28"	40 7/16"	6"	82.1	172	142	107	446	555
FORCETEAM07	25 3/4"	30"	40 7/16"	7"	82.1	207	171	128	533	620
FORCETEAM08	29"	30"	40 7/16"	7"	82.2	241	199	149	621	690

The Net AHRI Steam Ratings shown are based on a piping and pickup allowance of 1.333. The manufacturer should be consulted before selecting a boiler for installations having unusual piping and pickup requirements, such as intermittent system operation, extensive piping systems, etc.

Ratings shown are for installations at sea level and elevations up to 2,000 feet.

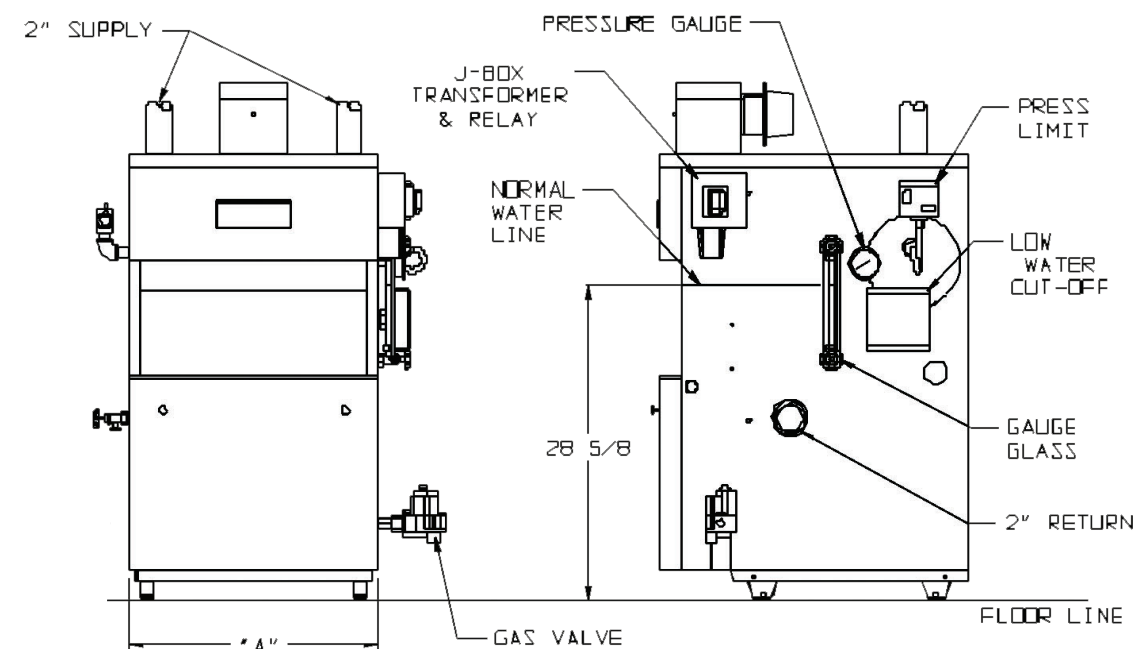

FRONT VIEW

RIGHT SIDE VIEW